

AZ764F

20 AMP HIGH TEMPERATURE MINIATURE POWER RELAY

FEATURES

- Quick connect Faston and PCB terminals
- Ambient Temperature up to 105°C (221°F)
- Dielectric strength 5000 Vrms
- Low height: 15.7 mm
- 20 Amp switching (18 A over Faston)
- Sensitive coils
- Isolation spacing greater than 10 mm
- Proof tracking index (PTI/CTI) 250
- Reinforced insulation, EN 60730-1 (VDE 0631, part 1)
EN 60335-1 (VDE 0700, part 1)
- UL, CUR file E43203
- VDE certificate 40012572



CONTACTS

Arrangement	SPST (1 Form A)
Ratings	Resistive load: Max. switched power: 600 W or 5000 VA Max. switched current: 20 A Max. switched voltage: 300 VDC* or 400 VAC * Note: If switching voltage is greater than 30 VDC, special precautions must be taken. Please contact the factory.
Rated Load UL, CUR	20 A at 250 VAC general use
VDE	10 A at 250 VAC resistive, 105 °C, 150k cycles 16 A at 250 VAC resistive, 105 °C, 10k cycles 20 A at 250 VAC resistive, 85 °C, 10k cycles
Material	Silver tin oxide
Resistance	< 100 milliohms initially

COIL

Power At Pickup Voltage (typical)	140 mW
Max. Continuous Dissipation	2.2 W at 20°C (68°F) ambient
Temperature Rise (at nominal voltage)	16°C (29°F)
Max. Temperature	155°C (311°F)

NOTES

1. All values at 20°C (68°F).
2. Relay may pull in with less than "Must Operate" value.
3. Specifications subject to change without notice.
4. Allow suitable slack on leads when wiring and do not subject the terminals to excessive force.

GENERAL DATA

Life Expectancy Mechanical Electrical (ohmic load at 105°C / 221°F)	Minimum operations 3 x 10 ⁷ 1.7 x 10 ⁵ at 10 A 230 VAC res. 2.8 x 10 ⁵ at 8 A 230 VAC res. 3.2 x 10 ⁵ at 6 A 230 VAC res.
Operate Time (typical)	7 ms at nominal coil voltage
Release Time (typical)	3 ms at nominal coil voltage (with no coil suppression)
Dielectric Strength (at sea level for 1 min.)	5000 Vrms coil to contact 1000 Vrms between open contacts
Insulation Resistance	10 ⁵ megohms min. at 500 VDC, 20°C, 50% RH
Insulation (according to DIN VDE 0110, IEC 60664-1)	C250 Overvoltage category: III Pollution degree: 3 Nominal voltage: 250 VAC
Dropout DC coils	Greater than 10% of nominal coil voltage
Ambient Temperature Operating Storage	At nominal coil voltage -40°C (-40°F) to 105°C (221°F) -40°C (-40°F) to 105°C (221°F)
Vibration	20 g at 30...500 Hz
Shock	30 g
Enclosure	P.B.T. polyester, UL-94 : V0
Terminals	Tinned copper alloy P.C. and quick connect
Max. Solder Temp.	270°C (518°F)
Max. Solder Time	5 seconds
Weight	16 grams
Packing unit in pcs	12 per carton tube / 600 per carton box

ZETTLER electronics GmbH

Junkersstrasse 3, D-82178 Puchheim, Germany

Tel. +49 89 800 97 0
Fax +49 89 800 97 200

office@ZETTLERelectronics.com
www.ZETTLERelectronics.com

AZ764F

RELAY ORDERING DATA

COIL SPECIFICATIONS - DC COIL SENSITIVE VERSION				ORDER NUMBER*
Nominal Coil VDC	Must Operate VDC	Max. Continuous VDC	Coil Resistance Ohm $\pm 10\%$	
5	3.75	15.0	102	AZ764FH-1AE-5DS
6	4.5	18.0	144	AZ764FH-1AE-6DS
9	6.75	27.0	330	AZ764FH-1AE-9DS
10	7.5	30.0	400	AZ764FH-1AE-10DS
12	9.0	36.0	580	AZ764FH-1AE-12DS
24	18.0	72.0	2,300	AZ764FH-1AE-24DS

* Substitute "FV" for "FH" for vertical quick connect terminals.

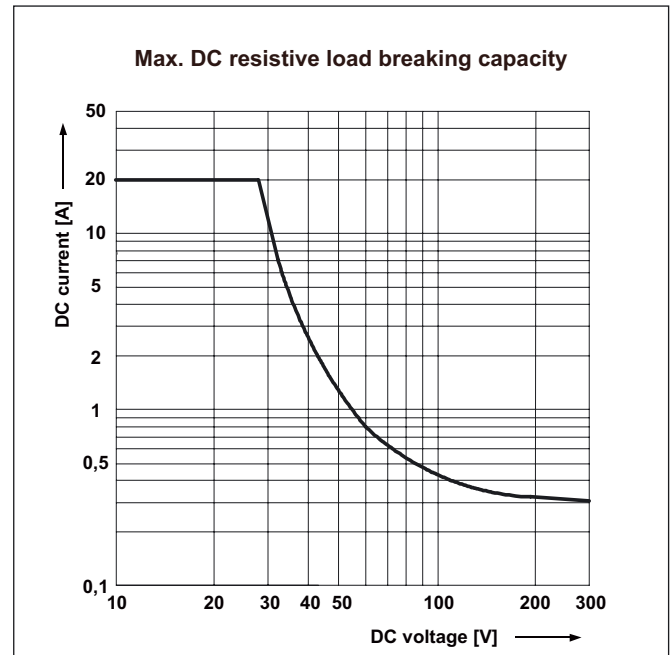
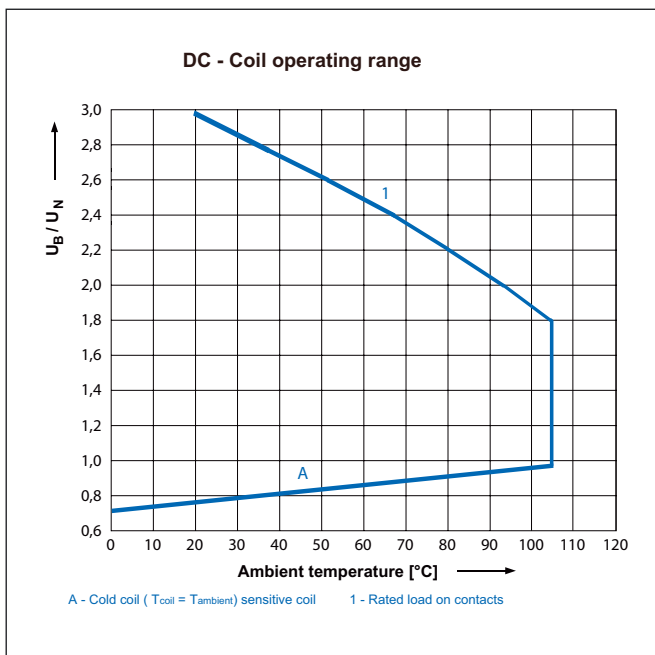
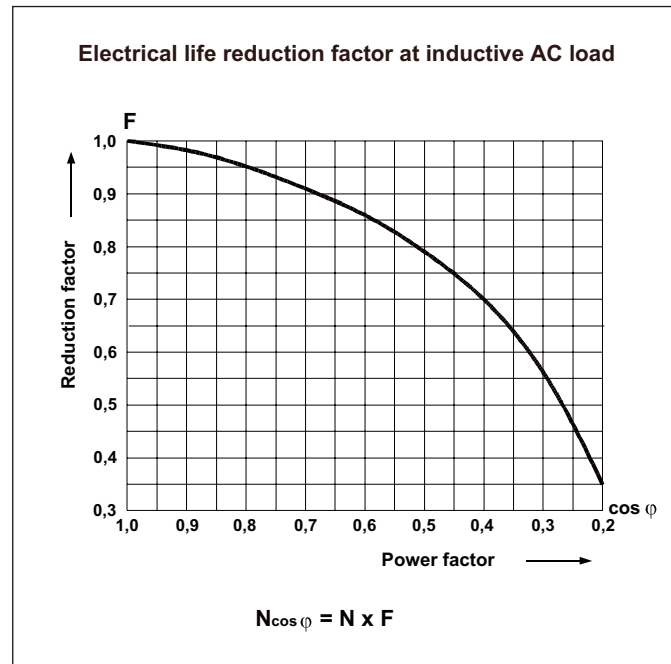
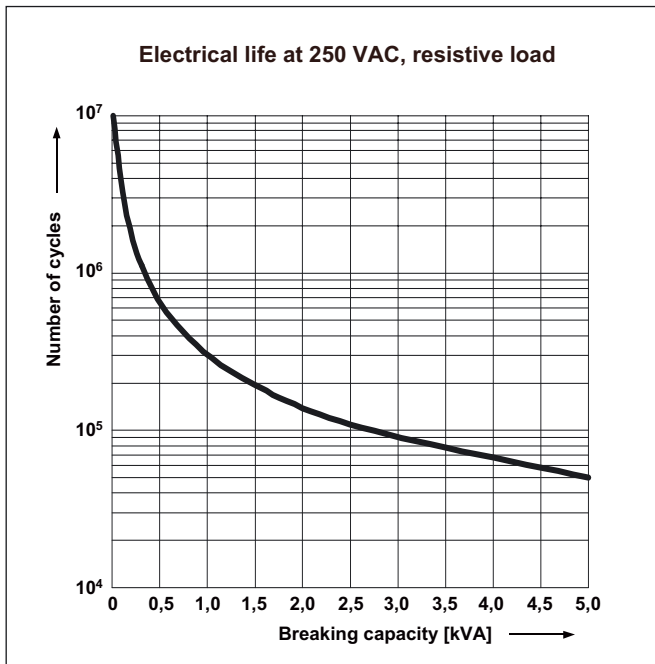

ZETTLER electronics GmbH

Junkersstrasse 3, D-82178 Puchheim, Germany

Tel. +49 89 800 97 0

Fax +49 89 800 97 200

office@ZETTLERelectronics.com

www.ZETTLERelectronics.com

AZ764F

MECHANICAL DATA AZ764FH - HORIZONTAL VERSION

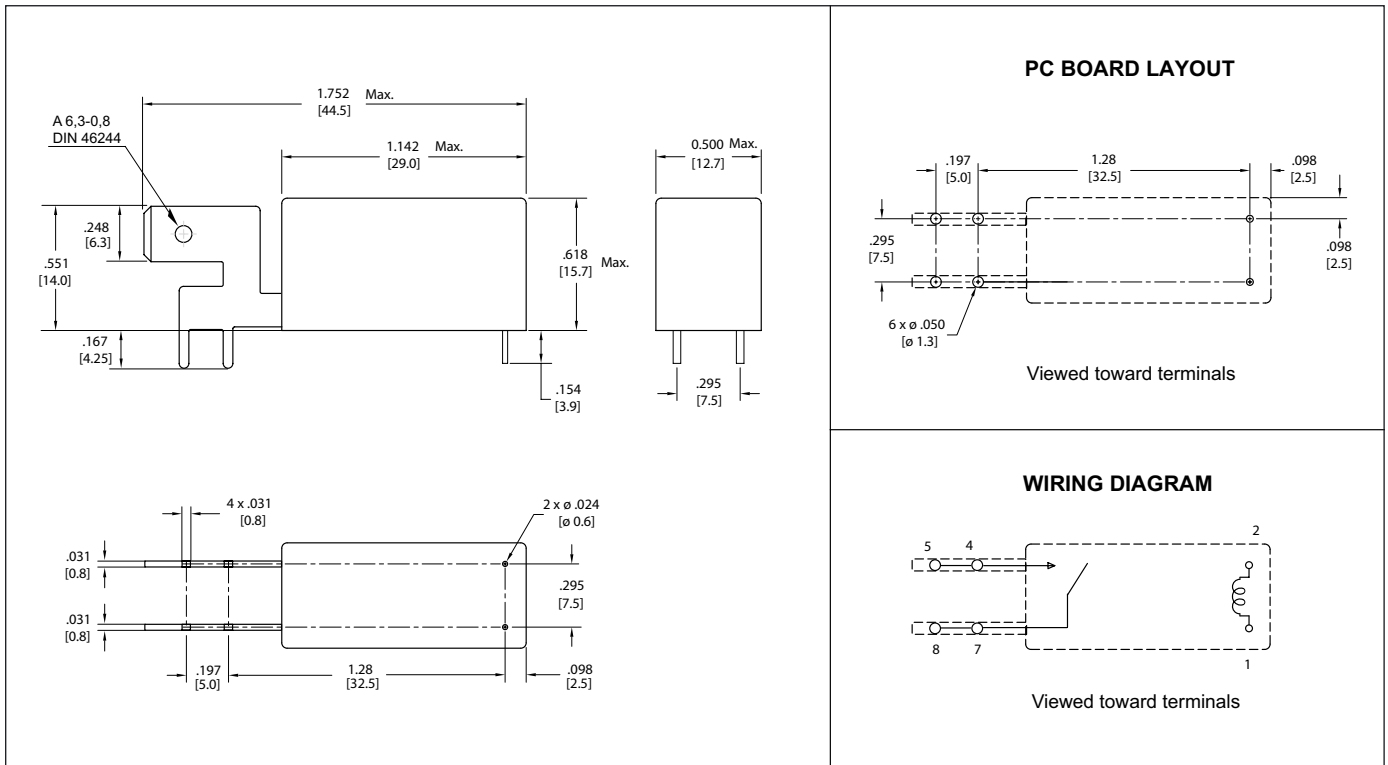

MECHANICAL DATA AZ764FV - VERTICAL VERSION

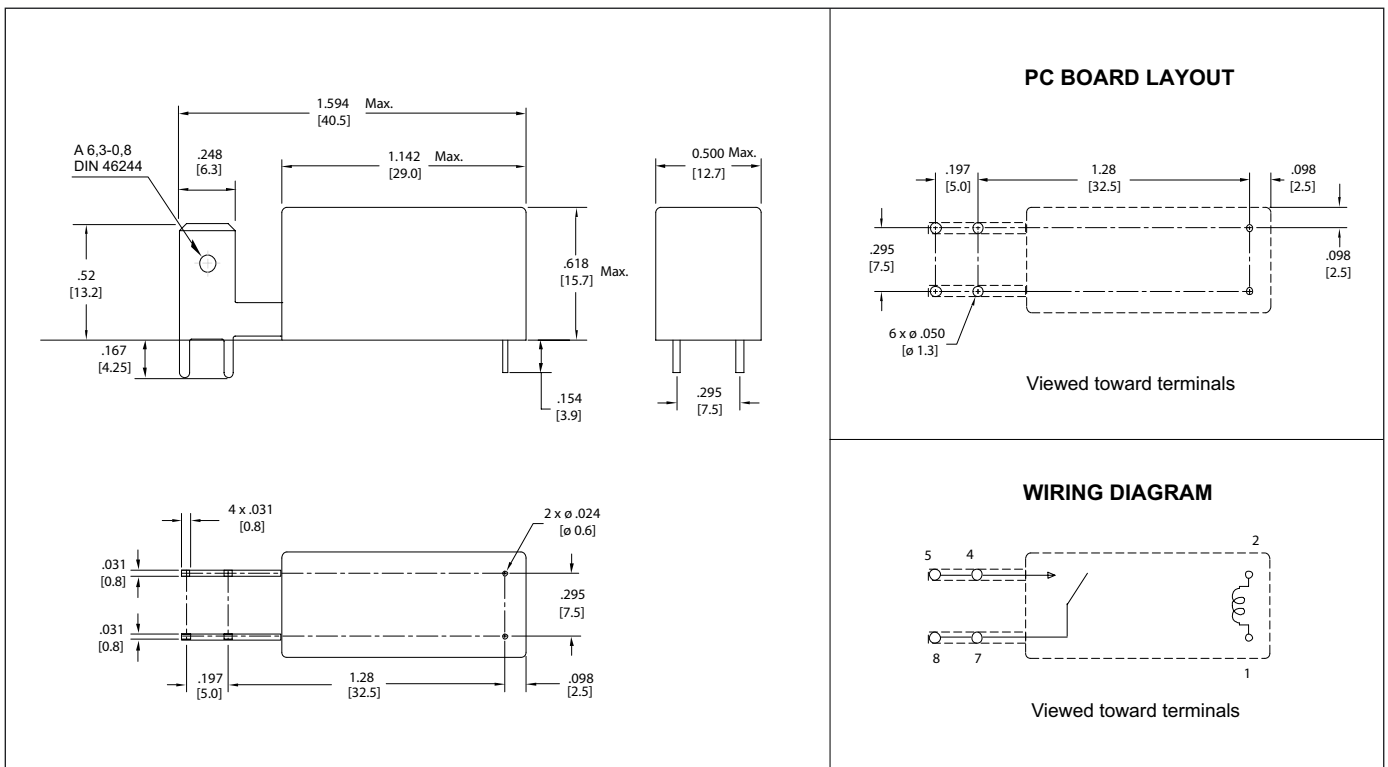

Dimensions in inches with metric equivalents in parentheses. Tolerance: $\pm .010''$

ZETTLER electronics GmbH

Junkersstrasse 3, D-82178 Puchheim, Germany

Tel. +49 89 800 97 0

Fax +49 89 800 97 200

office@ZETTLERelectronics.com

www.ZETTLERelectronics.com

2010-07-01